

ENGAGE NOW!

Creating Competitive Advantage to Broaden, Deepen and Diversify Participation in the Arts

For Creative Trust

Gerald D. Yoshitomi
MeaningMatters, LLC
November 2006

Describe a personally meaningful arts

experience (one in which you were not a principal artist, you might have been a spectator)

When was it?

Who was with you?

Describe with a Sensory Memory

or Metaphor/Simile (or just a word)

**What really counts is what you
learn after you know it all.**

Helen Hayes/Harry Truman

**If you always do what you've always done,
you'll always be what you've always been.**

Anonymous

**You can't solve a problem with the
same consciousness that created it.**

A. Einstein

Lateral Thinking

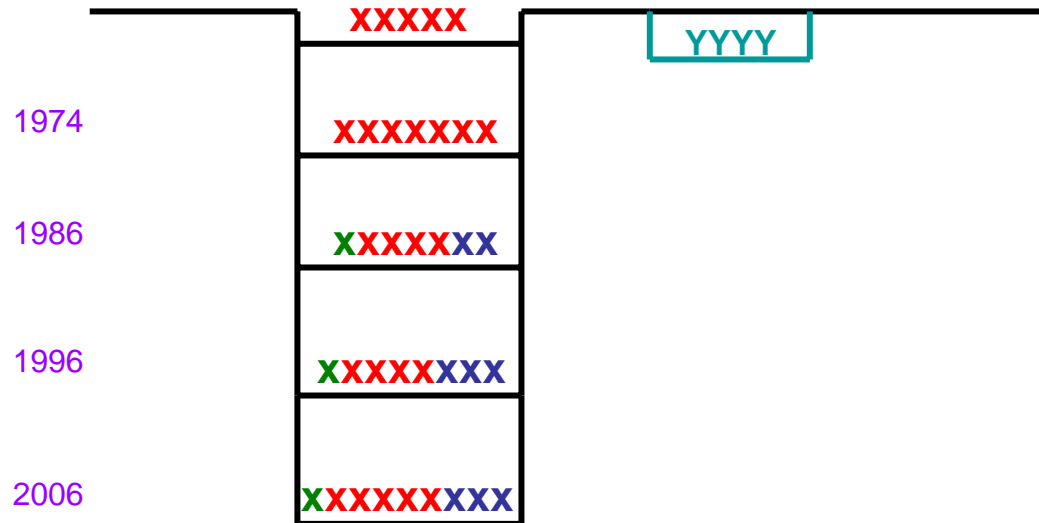

Systems Thinking – Counteracting Diminished Expectations (Senge)

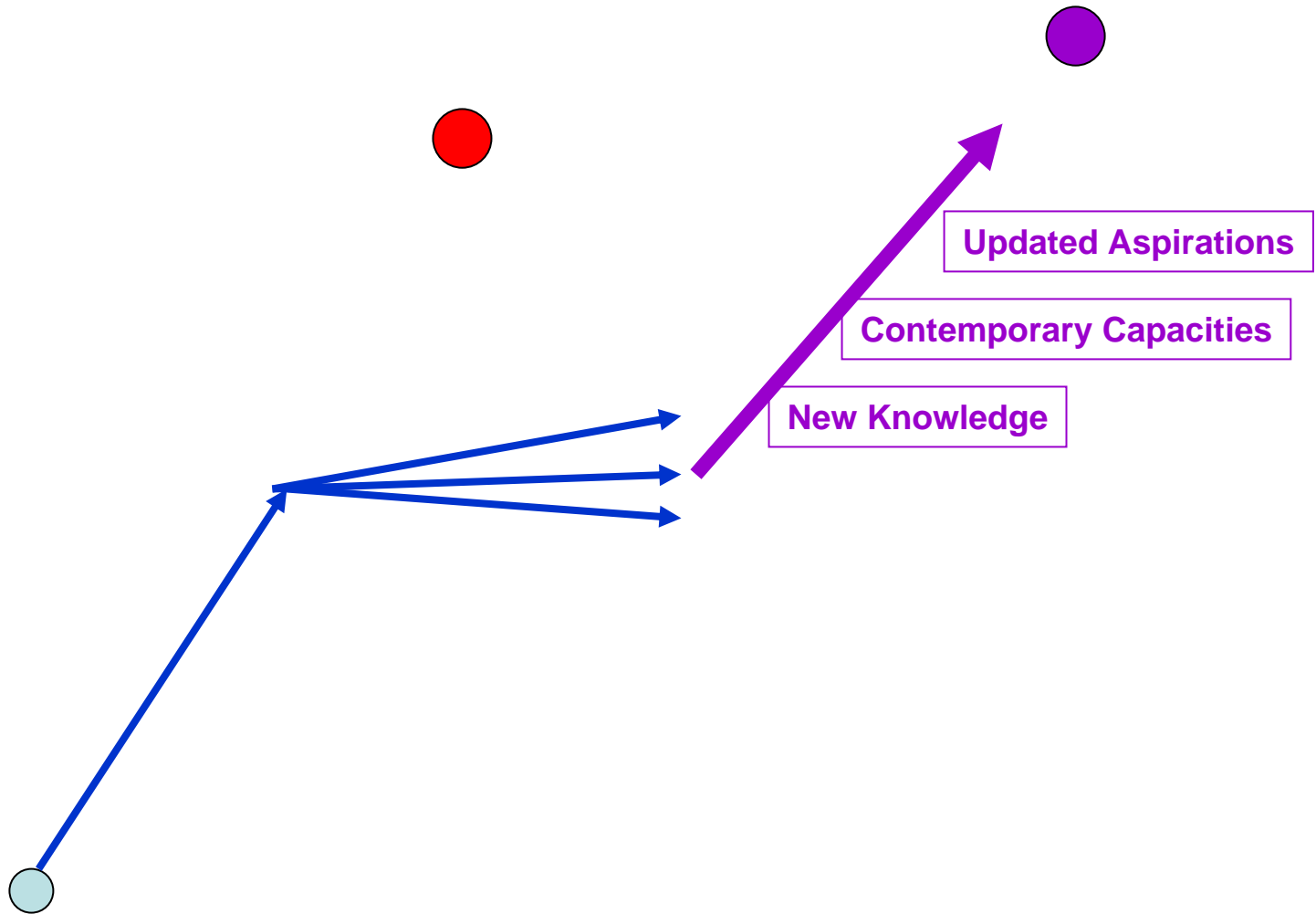

A framework for outside-in thinking: The Art of Scenario Thinking for Nonprofits

http://www.musicandmedia.org/standard/pdf/what_if_1.pdf

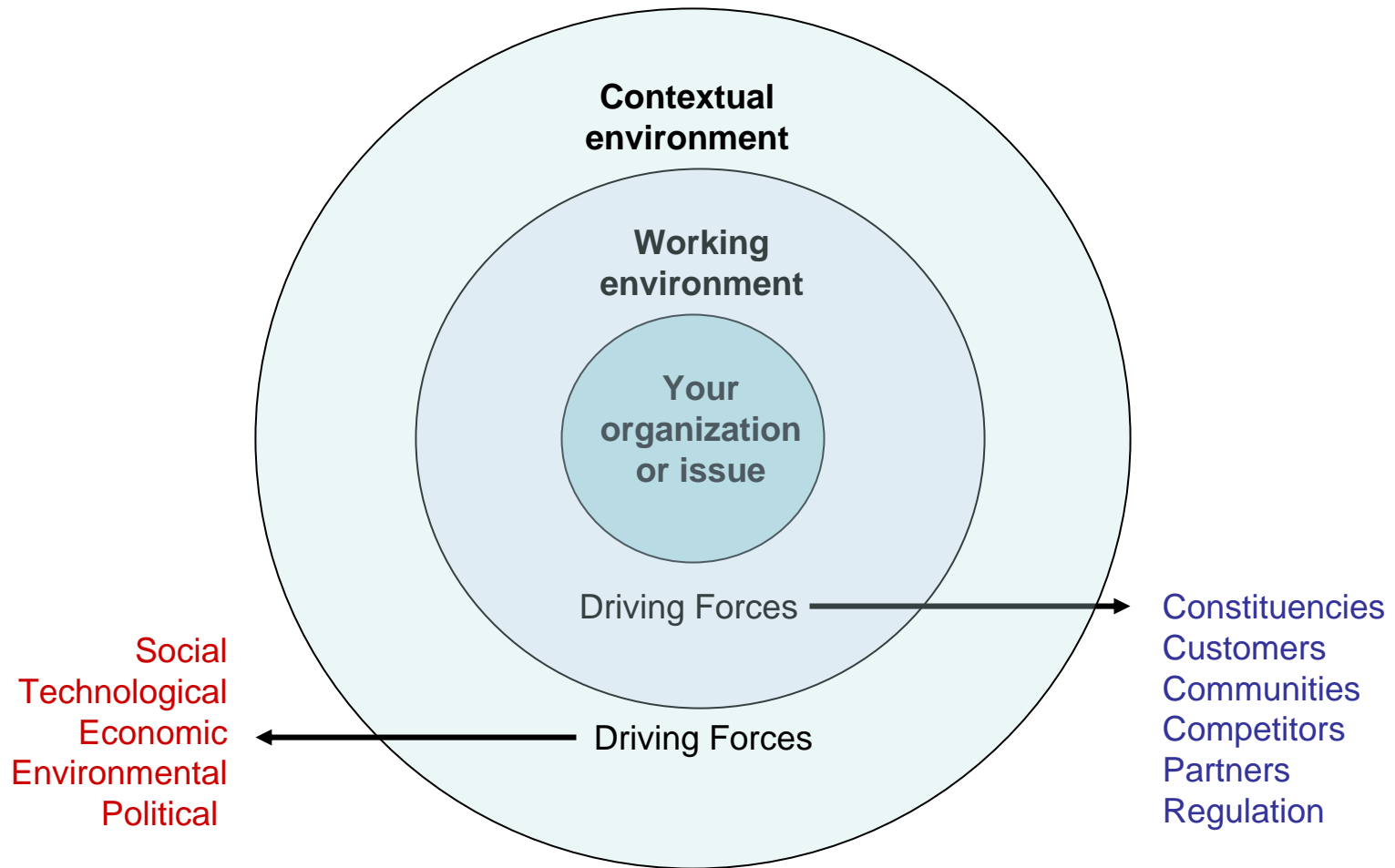

Living in Threshold Space – The Shuttle Zone

State of Stuck

Overwhelmed
Exhausted
Directionless
Hopeless
Battle-Torn
Worthless
Alone

**Prototypes/Experiments
“Liminal Space”**

New Knowledge

**Discomfort
Failures/Lab Notes**

Current Practice

New Practice

FINDING THE INNOVATORS

Innovation Diffusion Curve

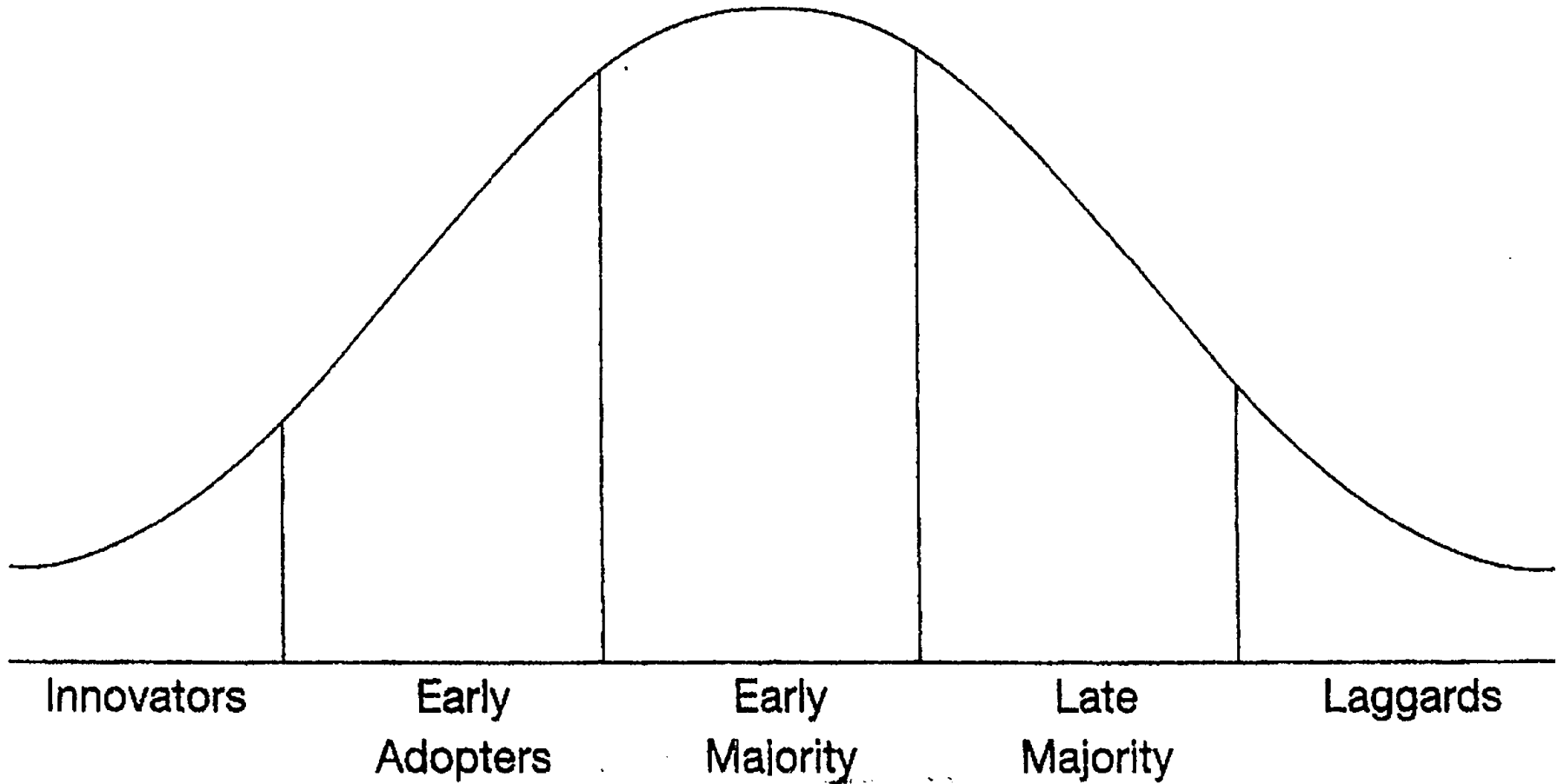

More Often 15% Reasons Why

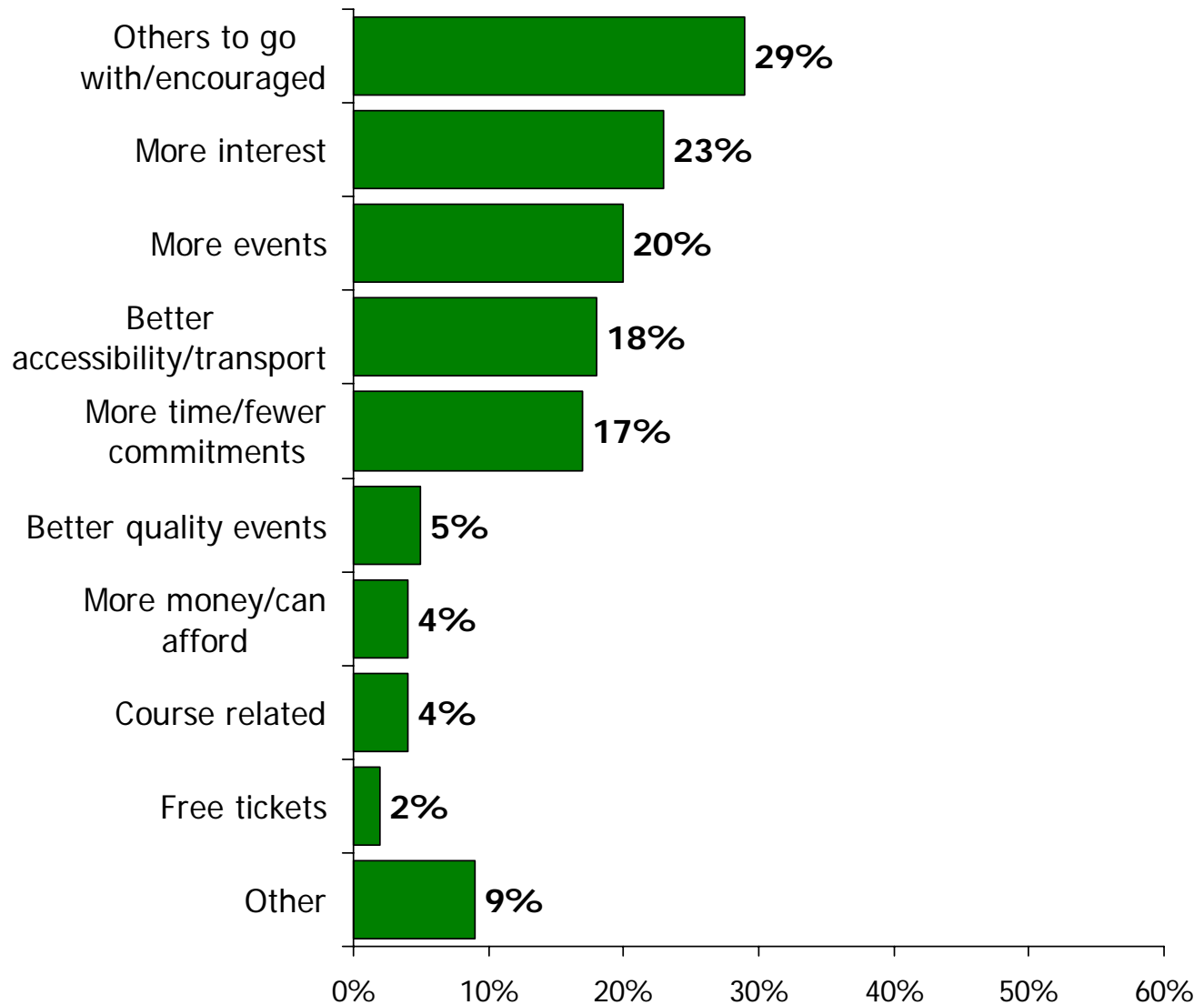

Less Often 19% Reasons Why

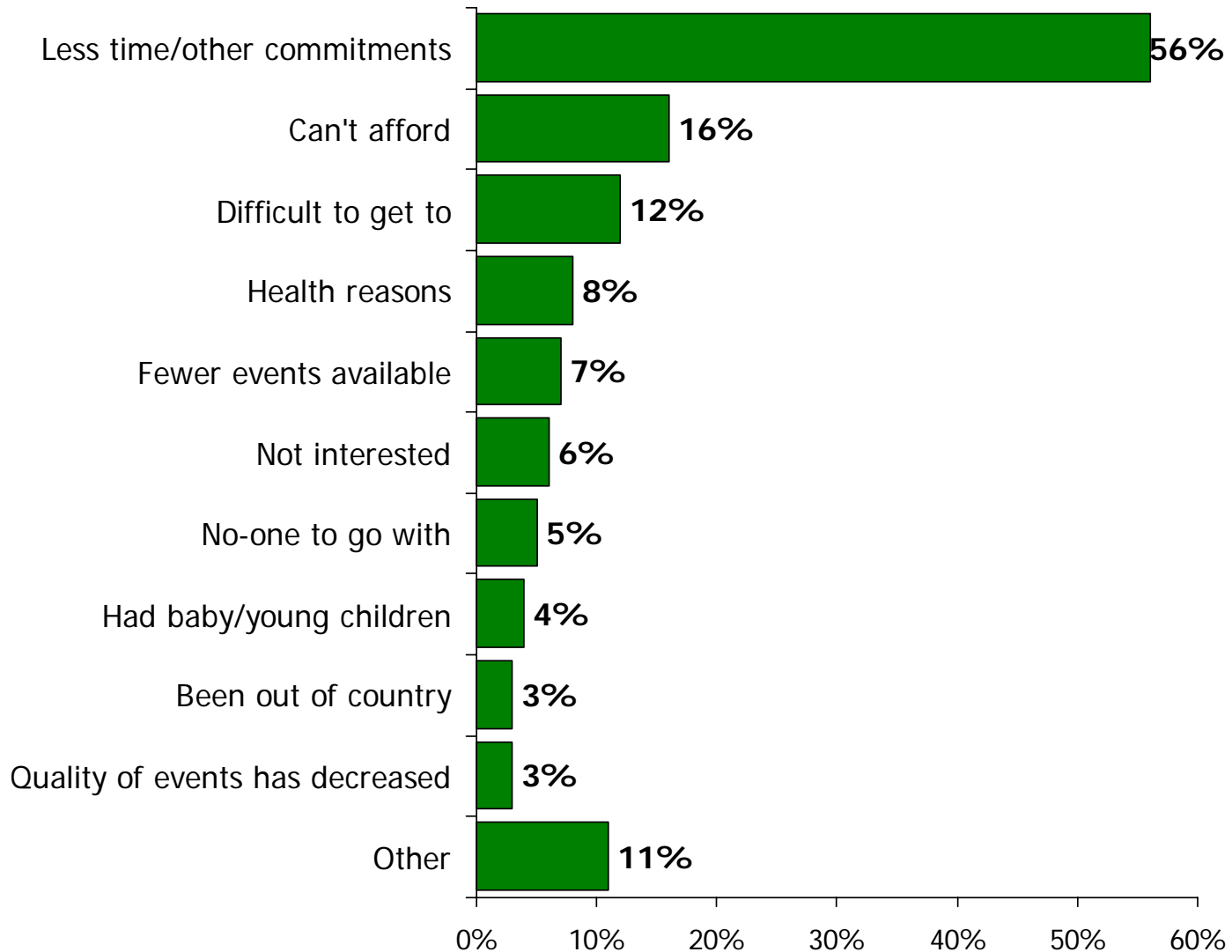

Behavioral Model of Participation (by McCarthy & Jinnett -RAND)

Attributes/
Backgrounds

Perception of benefits
of participation

Practical
Barriers or
Enhancements

Participation
Experience

Reaction to
Experience

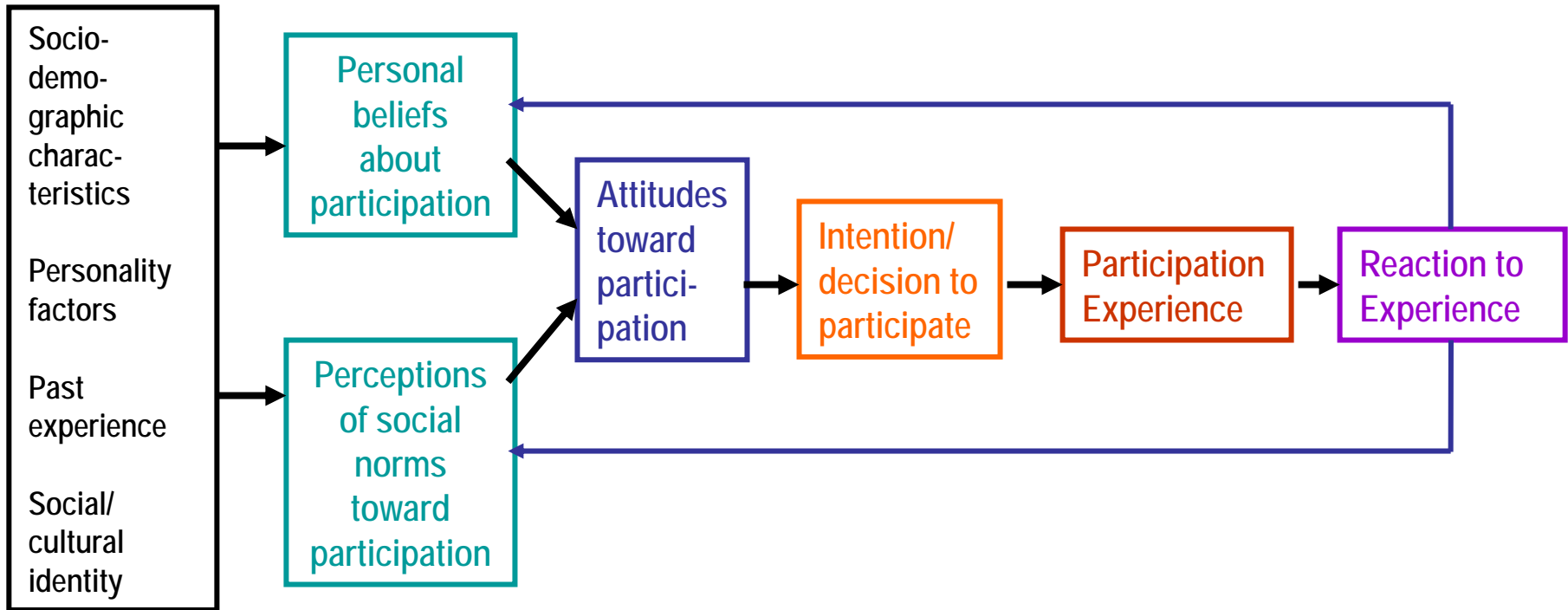

Benefits: Outcomes for Participants/Families/Relationships/Communities/Artforms

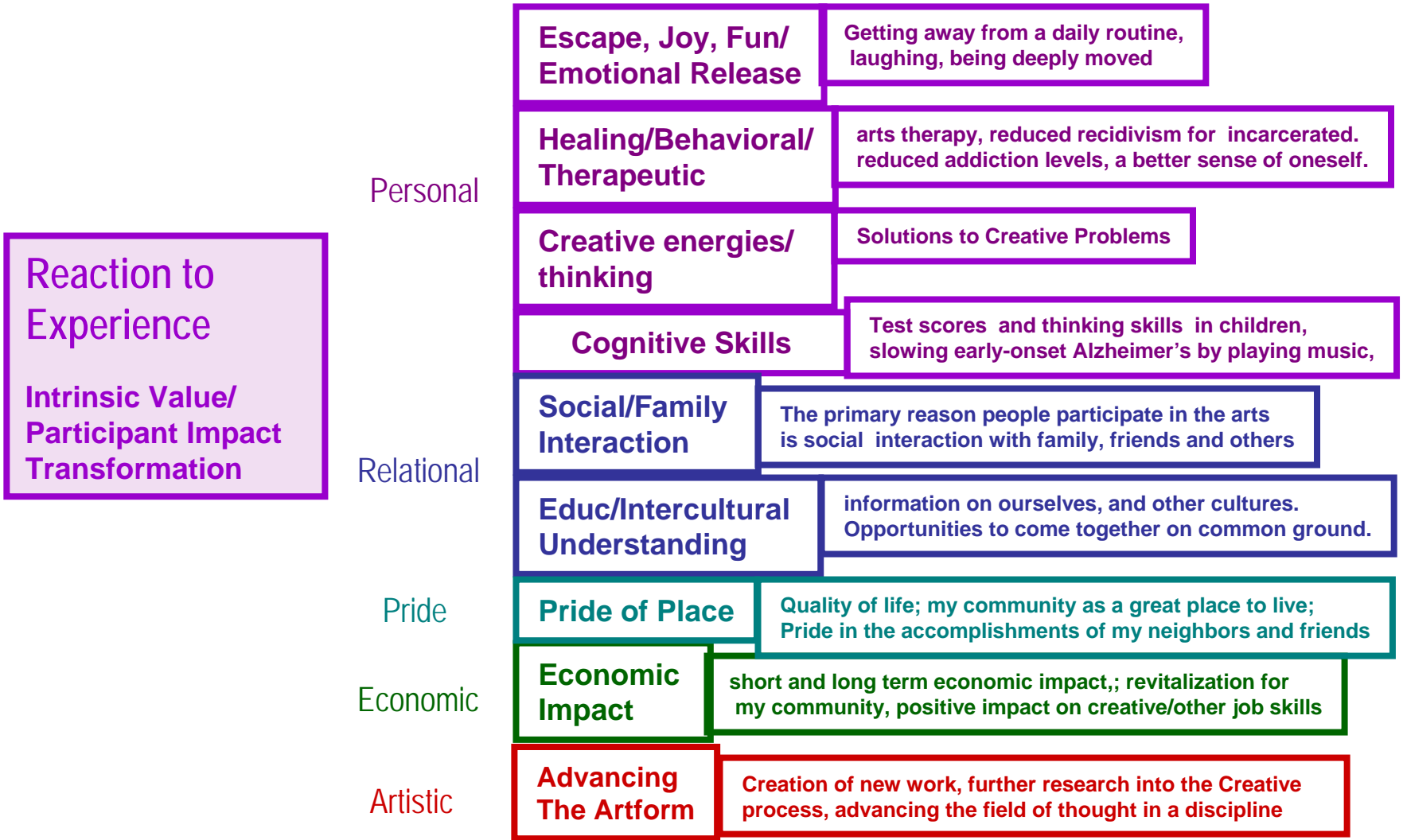

See Appendix: McCarthy, Kevin, *Gifts of the Muse: Reframing the Debate About the Benefits of the Arts* & Brown, Alan: *Values Study*, for the Connecticut Commission on the Arts

The Value System Surrounding Arts Participation

Alan Brown, Values Study for Connecticut Arts Commission

Figure 4: The Value System Surrounding Arts Participation

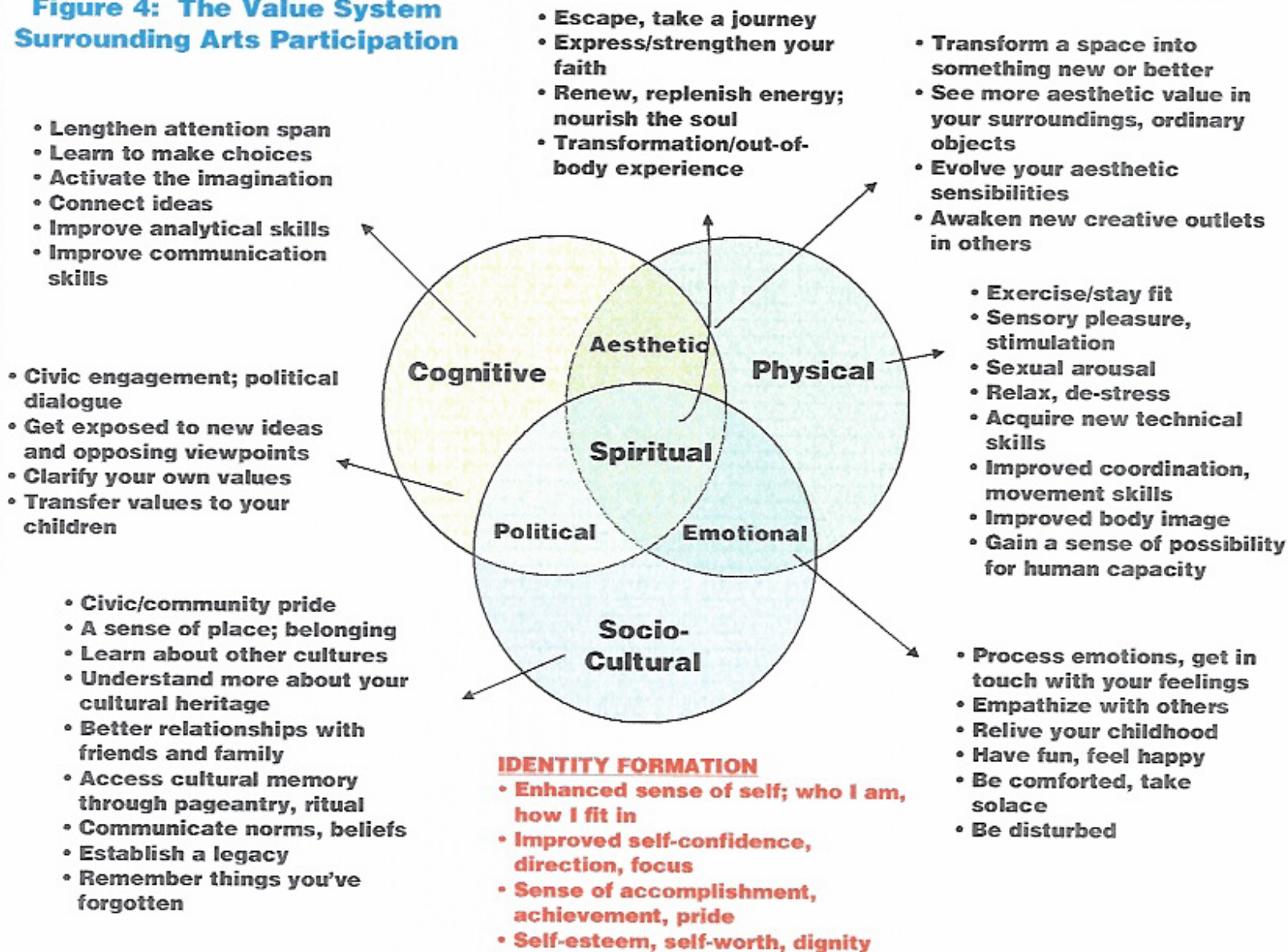

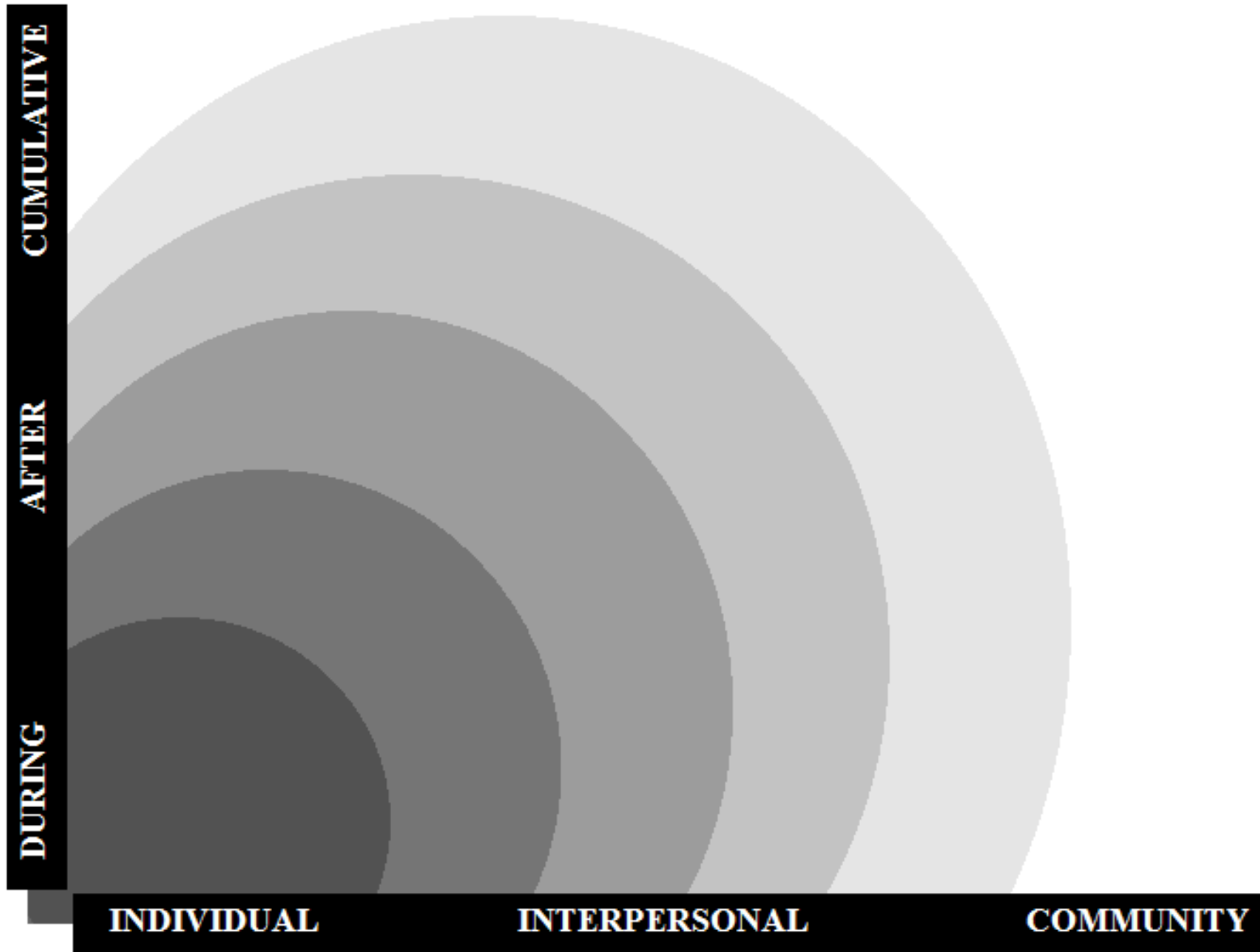

Four Dimensional Marketing - Thomas Gad

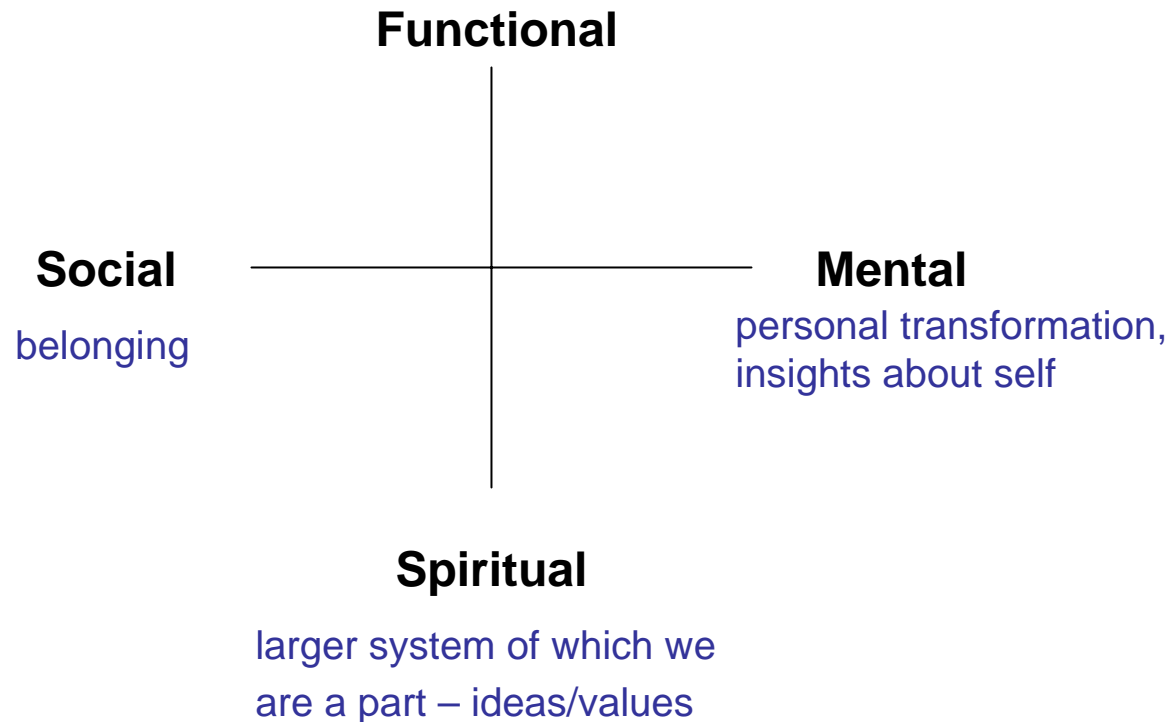

What are the values/vision of our organization?

How do we communicate them? (Perception of Benefits)

How do we advance them? (Practical Strategies + Experiences)

Flow (From Csikszentmihalyi)

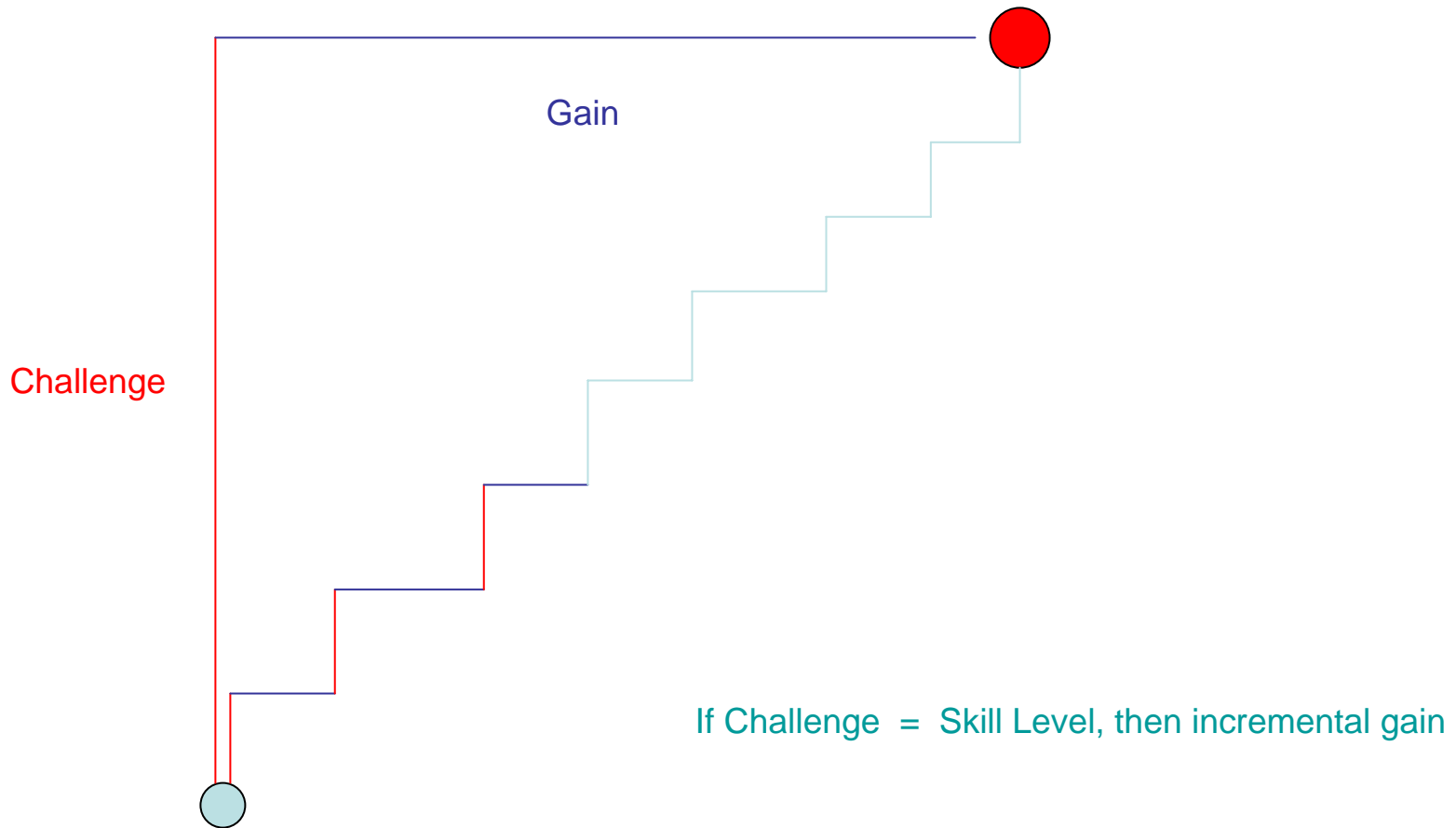

Multiple Generations (J. Walker Smith)

Matures (61+)

Boomers (43-60)

Xers (27-42)

Echo-B (Under 27)

Differences

Ethnicity

Media – Multi Channel

Gen Specific Language

View of Institutions

Marketing Resistance

Single Households as Norm

New Methods

Word of Mouth/Postcards

Viral E-Marketing

Multiple Channels

Influencers/Initiators

Children's Choices

Segment Managers

[http://www.quickdfw.com/
about/](http://www.quickdfw.com/about/)

Reciprocity - Obligated to give back those who've given to us

Consensus - Decide what's appropriate by examining what others do – social identity theory

Authority - Rely on superior knowledge for guidance

Consistency - Once making choice/stand, personal & interpersonal pressure to be consistent with that commitment.

Scarcity – Opportunities appear more valuable when less available

Liking - Say "yes" to those we know/like (or who like us)

The Contrast Phenomenon

Timing

It's all about Me! (not you, them!)

People Need to Believe

People Need to Belong

People Seek to Contribute

People Seek Transcendence

Review of the Behavioral Model of Participation

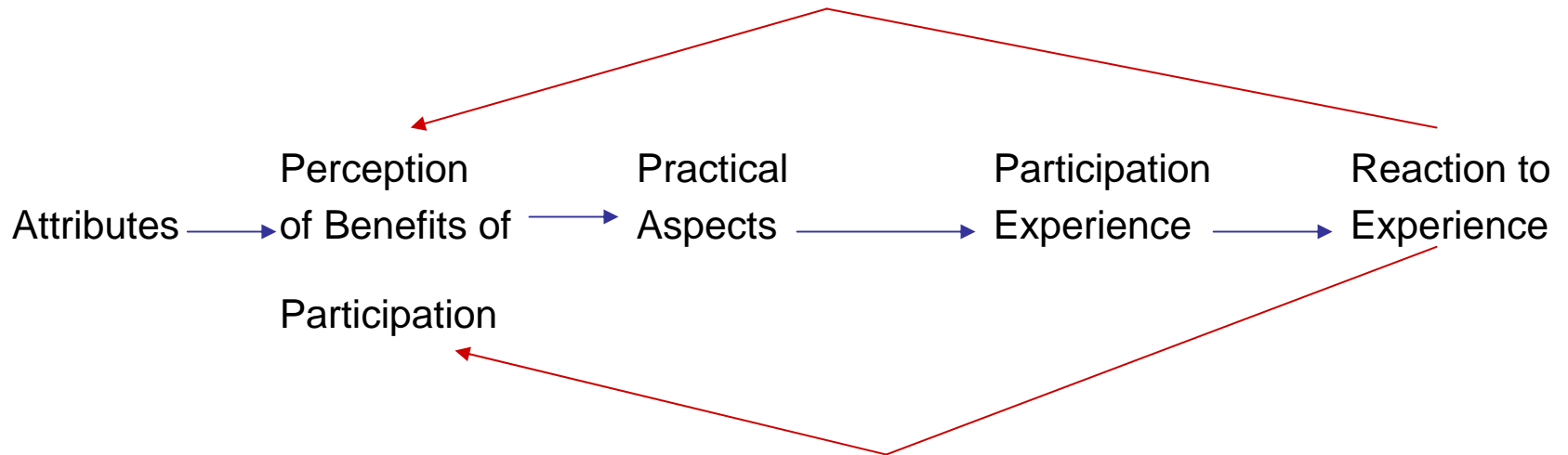

Participation Behaviors

Whose (what group) behavior do you want to influence?

– What segment?

What do you want them to do? - Intended Behavior

What are their Attributes & Current Behaviors

What New Strategies would you suggest?

- Perception of Benefits
- Practical Aspects
- Experience
- Reaction to Experience

What evidence would to gather to demonstrate success?

Describe a personally meaningful arts

experience (one in which you were not a principal artist, you might have been a spectator)

When was it? Who was with you?

Describe with a Sensory Memory or Metaphor?

What was the personal benefit or value to you,
your friends, family or community?

Transactional Framework

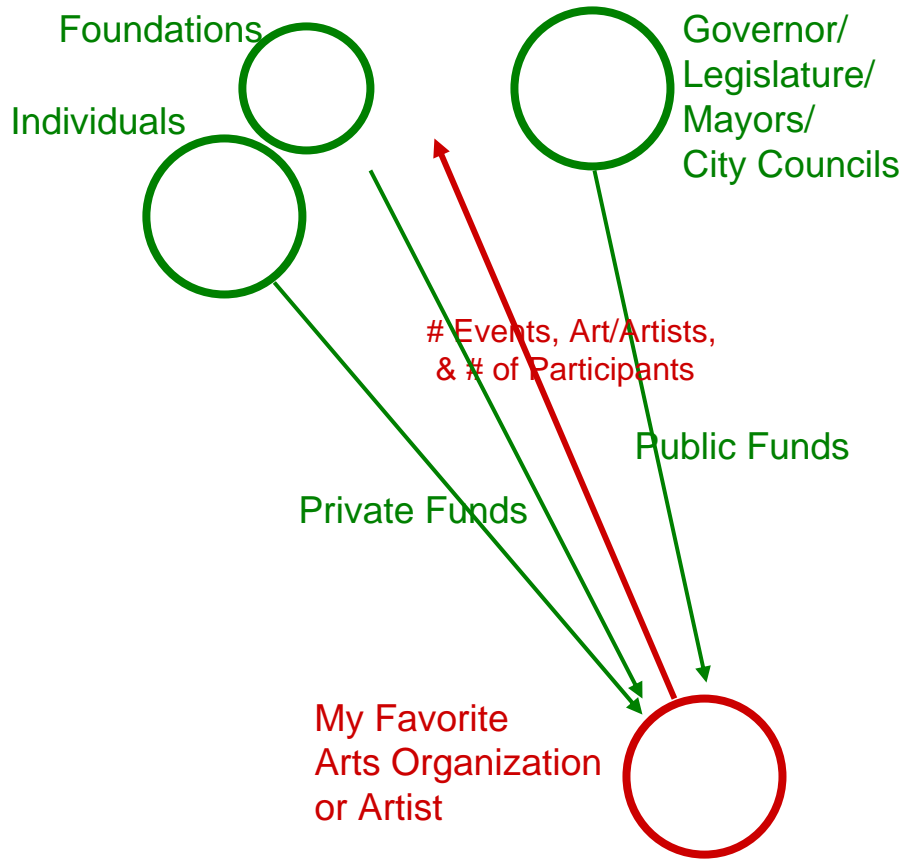

Benefits, Participation and Public Value (BPPV) Triangle

Mark Moore – *Creating Public Value*

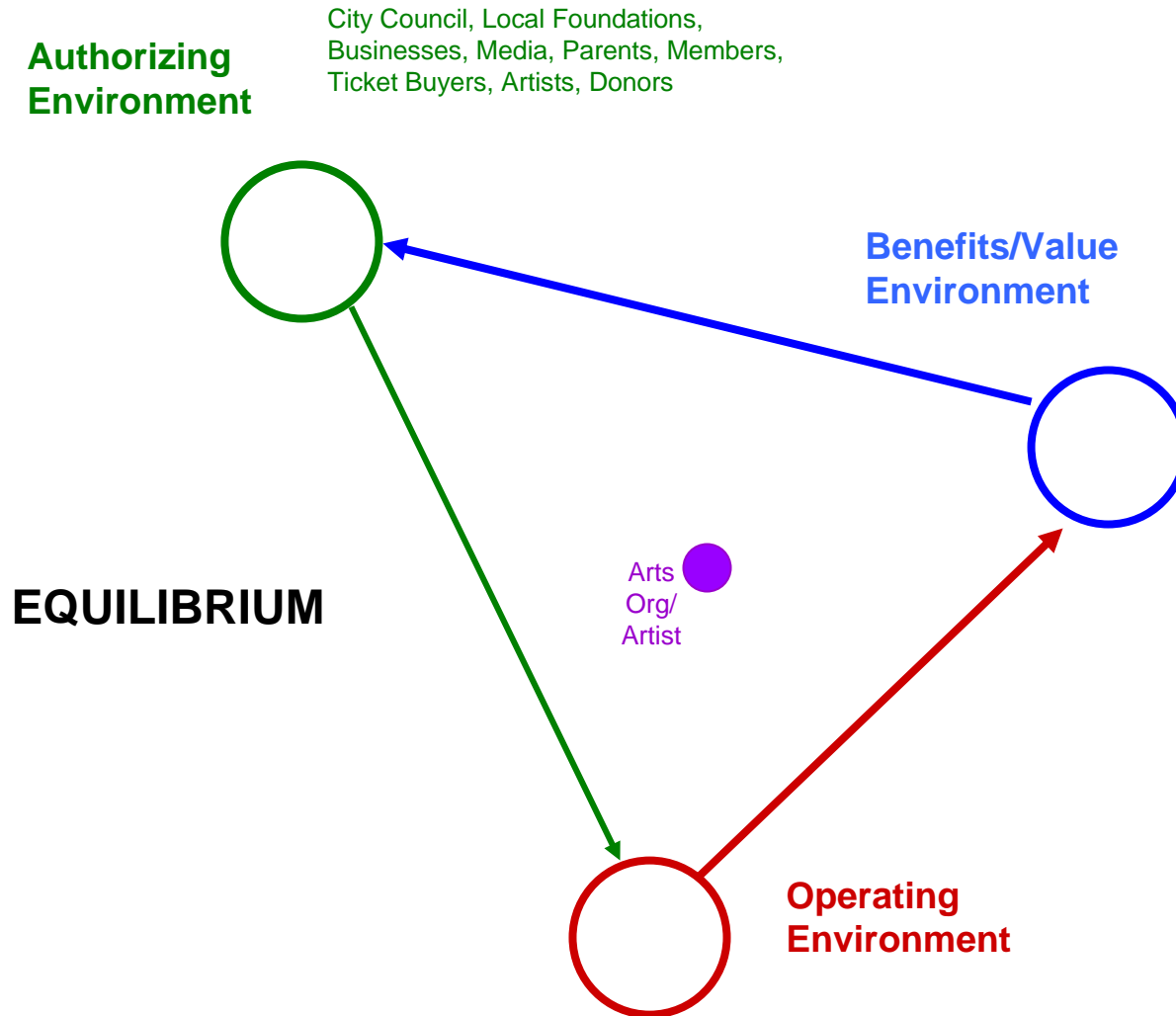

Benefits: Outcomes for Participants/Families/Relationships/Communities/Artforms

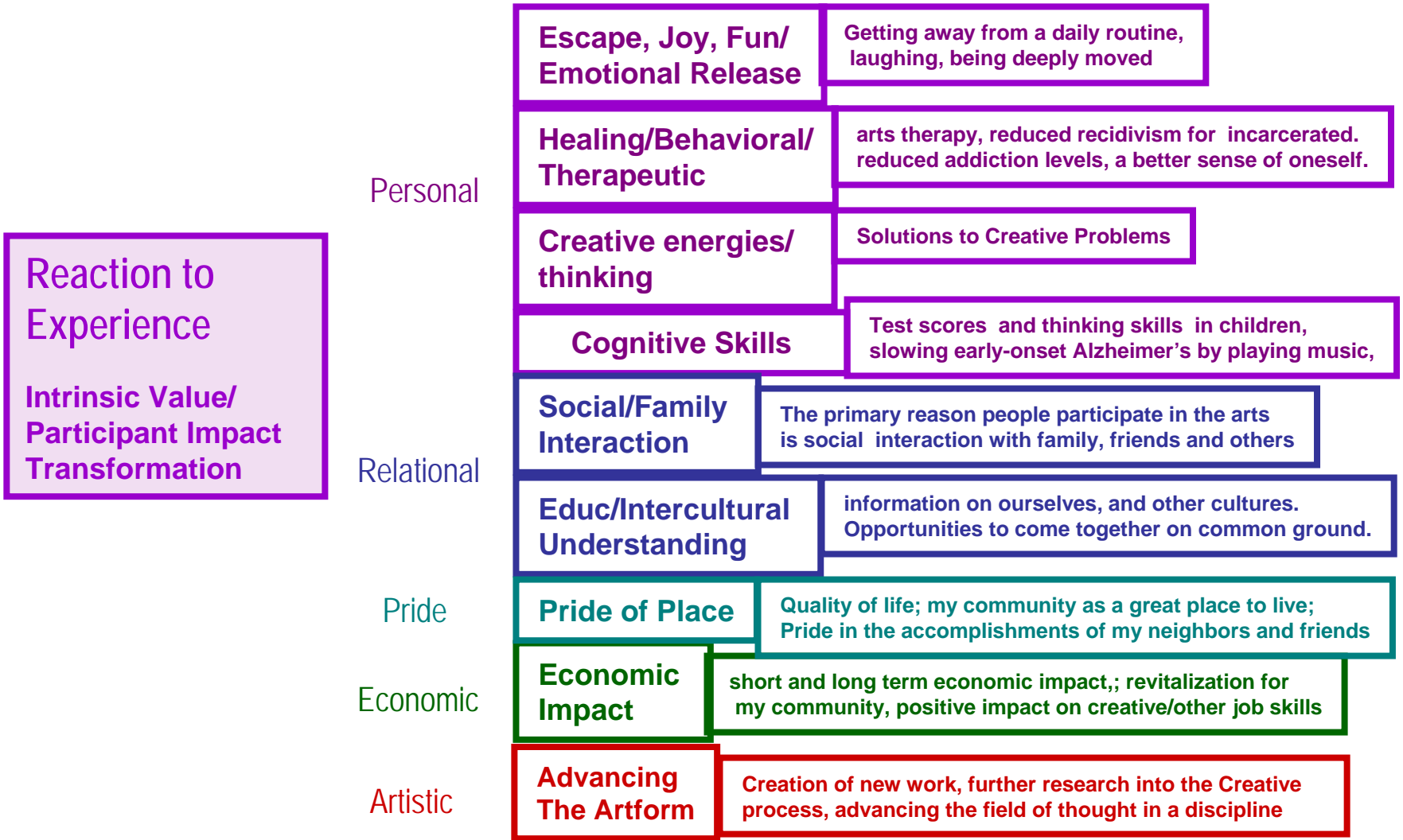

See Appendix: McCarthy, Kevin, *Gifts of the Muse: Reframing the Debate About the Benefits of the Arts* & Brown, Alan: *Values Study*, for the Connecticut Commission on the Arts

Personal Benefits/Public Value of the Arts

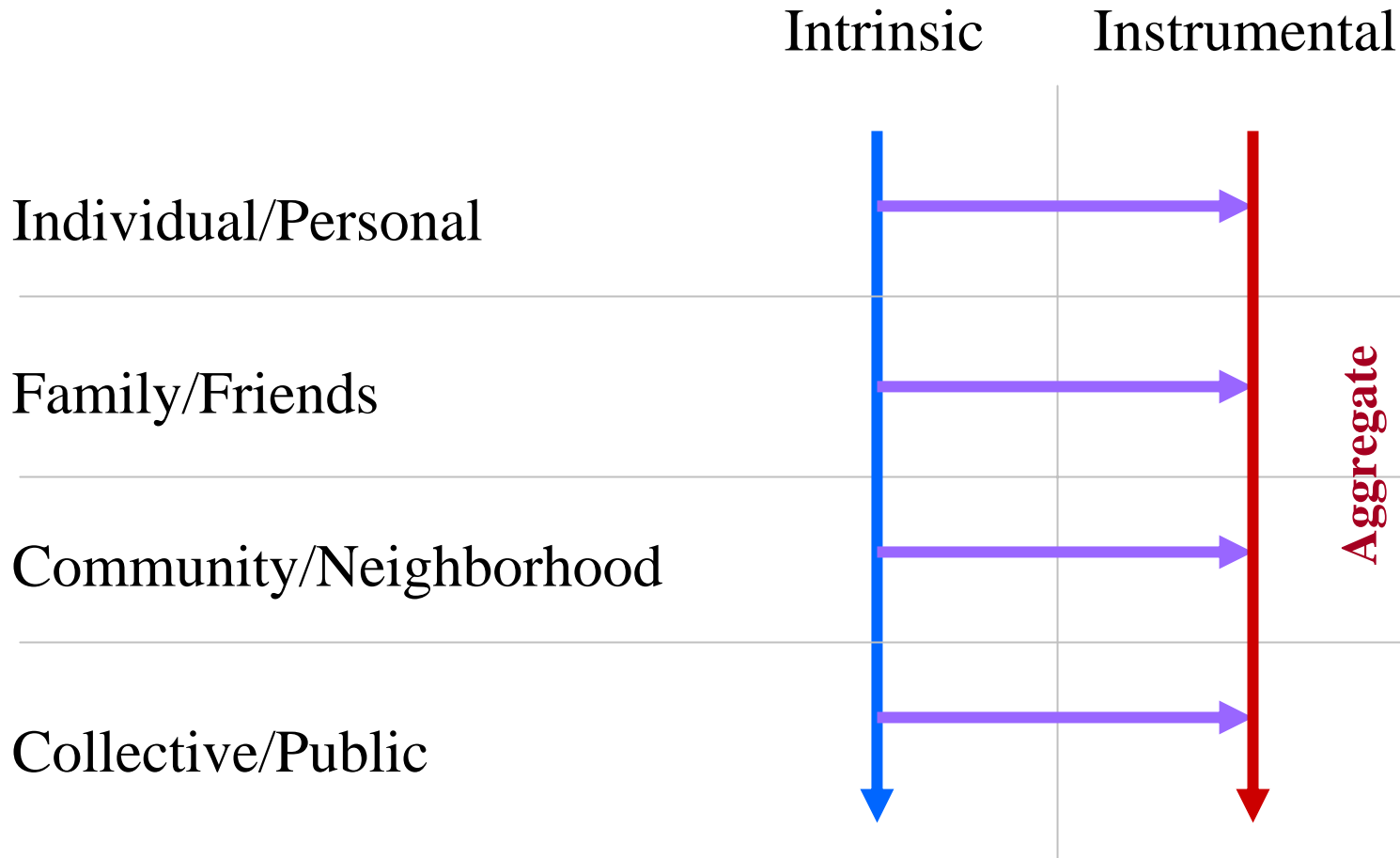

Intrinsically Valuable Experience: Of value for its essential nature, of value in and of itself

Instrumentally Valuable Experience: Serves as means or an aid in achieving a goal or objective

Different impacts are important to different groups



Authorizers

Mayors - Livable Communities

Chambers - Jobs/Economic Dev

Parents-Happy/Healthy Kids

Faith Based -Strong Families

Tourism Industry – Visitors

Artists

Workforce/Unions

Rural Leaders - Access

People (Me)



Transformational Framework

Benefits, Participation and Public Value Triangle

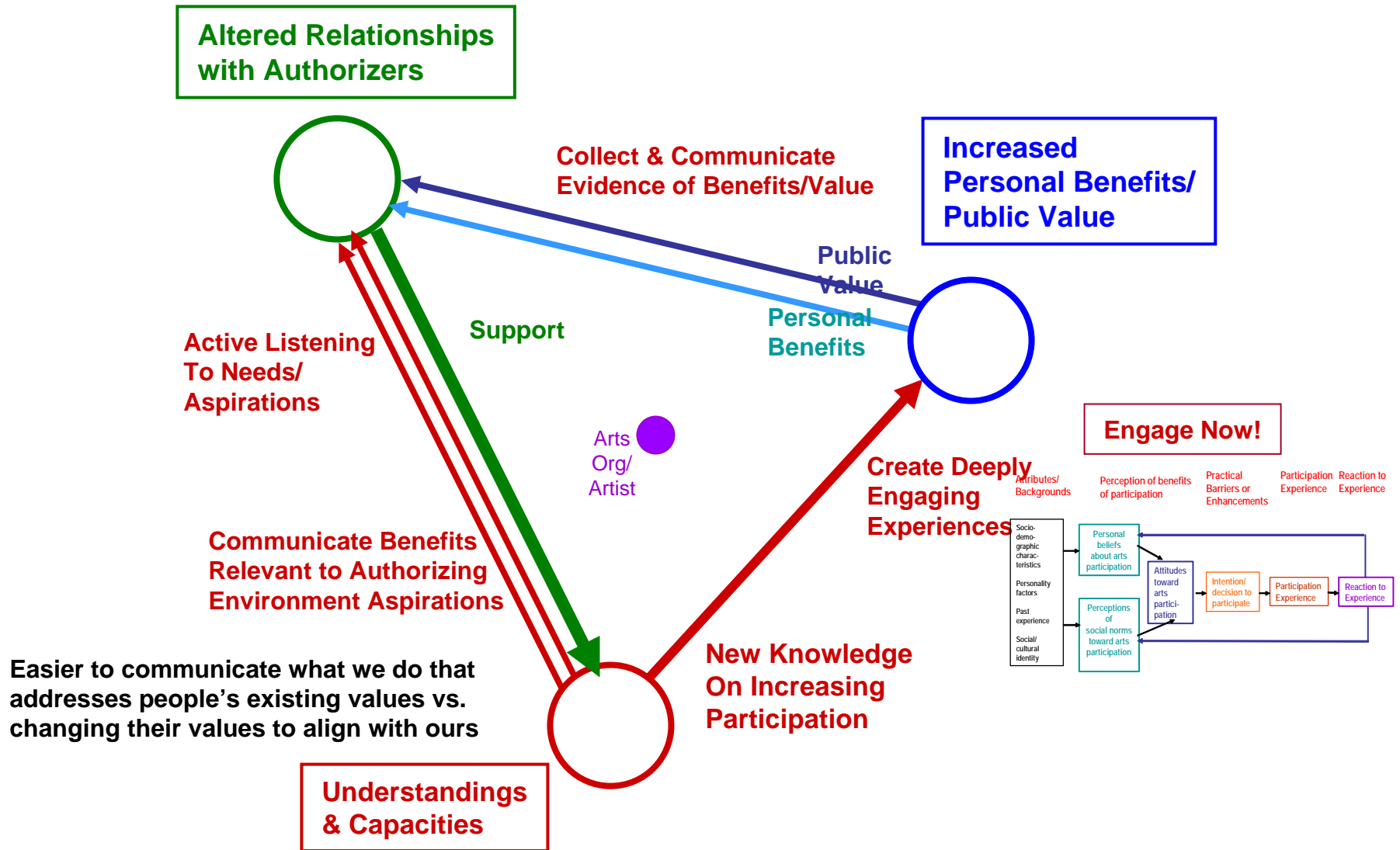

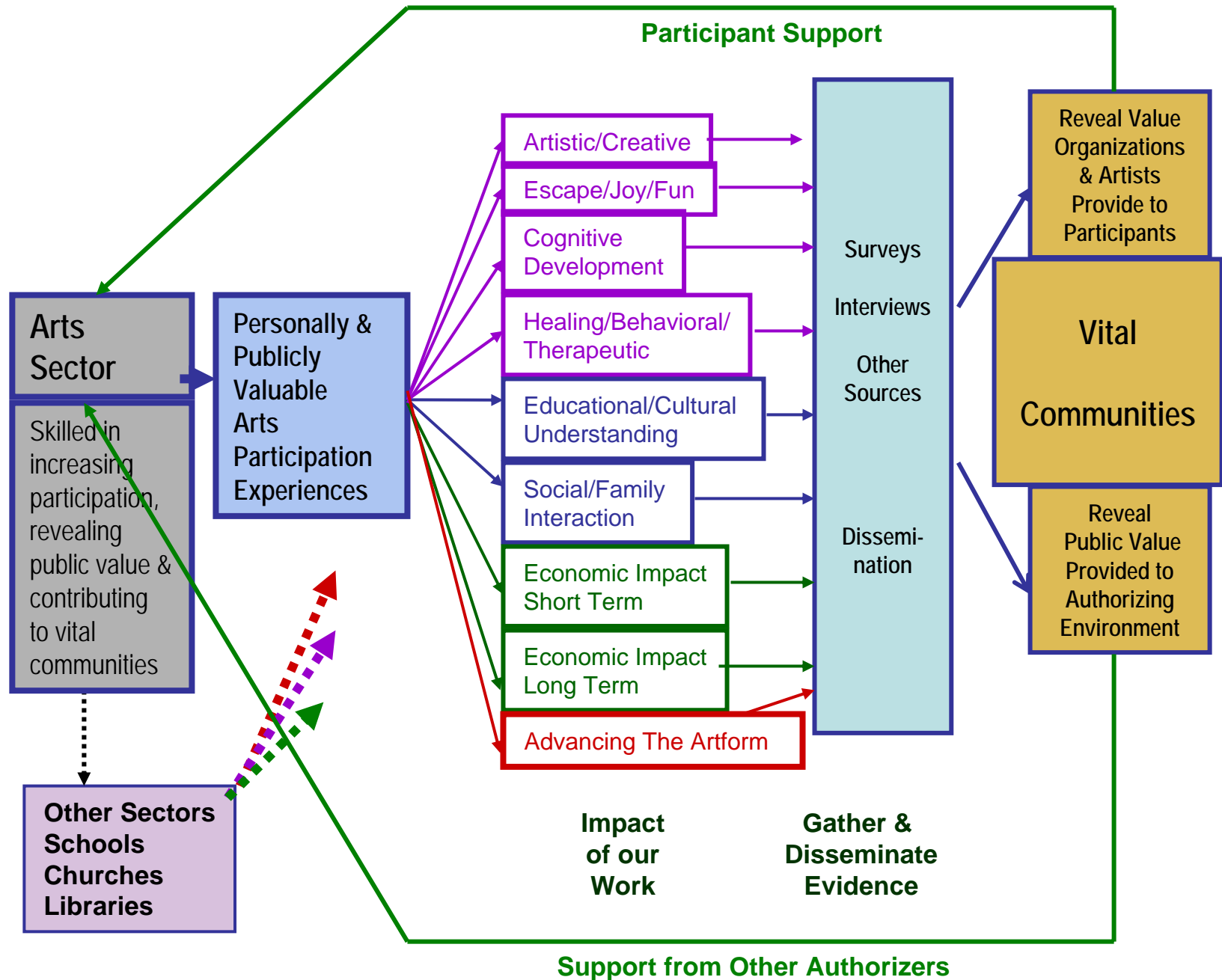

The Long Tail

http://longtail.typepad.com/the_long_tail/



“Addressed painful issues in a way that left me excited and INSPIRED about life.”
REVERAND RUTH SEGAL

“It REVITALIZED me and reminded me how important it is to spend money on live, quality entertainment.” - JUDITH MADER

“Gained new insights into classical music. I took pleasure in watching many working together as one without losing their individuality.” - CARON CADLE

“As is the case with art that moves you, as always, we realize how insignificant we are when we are subjected to an experience such as this. A more correct word would be ‘VULNERABLE’ instead of insignificant.”



“I was really in a stressful point in my studies and experiencing the joy, LOVE and talent of the choir helped me to better deal with those situations that I let attack my spirit.”
LEAH EVELYN WOODWARD



“An ESCAPE from the everyday responsibilities takes place while listening to music.”
JANE AND FRANK FLORENCE



“The world is a BETTER place because of this level of music.”
TOM LOGAN

- wonderful to see ballet done so beautifully.
- Made me feel exhilarated
- warm & fuzzy feeling
- beyond great! took the crowd's breath away.
- the whole evening was so much fun, Bring that show back!
- Wonderful experience, full of emotion and sentiment.
- Stimulated, excited after the performance wishing and wanting more
- a beautiful auditory and visual experience
- Entranced and mesmerized
- cannot be missed. Anxiously awaiting repeat performance,
- warm and relaxed and then vitalized
- reminded me of previous times spent with my family and children.
- the performance was fantastic. awesome costumes & set.
- one of the rare transcendent experiences
- phenomenally beautiful, and a great recollection and release
- not able to share many heart warming moments with my father - wonderful to spend time together with our mutual love of music.
- talked about it for weeks/felt special connection having been together

Voted "BEST LIVE THEATRE" Four Years in a Row!



The Port Theatre won a STERLING AWARD FOR SERVICE in 2005. When nominating us, Robb Mowbray of Theatre BC said "The Port Theatre Society has done a tremendous job of managing Nanaimo's crown jewel in the heart of downtown. They have surpassed expectations, brought a wonderful variety of performances to our city; they are leaders in the arts community!"

BEST OF THE CITY



Mamy Sikitu moved to Nanaimo from Congo and was skeptical when first attending the Theatre. "I thought it might be boring, but I was impressed. The show was mesmerizing! It was no longer about my birthday or my new outfit; it was a whole new experience. I recommend anyone give it a try, you'll be amazed."

12-year old Brittany Barraclough was thrilled to meet Karen Kain with The National Ballet. "I will be taking my grade 5 ballet exam this year; Karen inspires me to dance better. When I gave her a rose she gave me a hug!"



Sponsoring a "Port Presents" event was one of the best things we've gotten involved in! Our support was appreciated and our business benefited from the experience. Two thumbs up! - Patrick Belanger, VP - Webacom Media Corp.



"What a wonderful evening listening to our favourite Canadian singer/songwriter Ian Tyson! We become involved with the whole song...he reached into our hearts. We could feel the wind and smell the prairie in his music." - Sandi and Tom Horton



Attending the Chilliwack concert encouraged 12-year old aspiring musicians Riley Anderson and Jesse Dunbar to "someday be in a famous rock band and play all over the world!" Their favourite memory was Bill Henderson giving them a guitar pick after the show.

The Central Vancouver Island Multi-Cultural Society often introduces new members of the community to The Port Theatre through our Theatre Angels program. Navaraj Koirala, Horst & Christina Hoeger, and Jennifer Lo Roberts have all enjoyed and benefited from a Port Theatre experience during the last year!



Voted "BEST LIVE THEATRE" Four Years in a Row!

BEST OF THE CITY



"My favorite Port Theatre moment was the first year of the Festival for Young Audiences - The Gala Opening. There was a Cuban acrobatic troupe performing. A young Cuban performer, beautifully miming monkey motions, turned the Port Theatre audience into a part of the jungle by climbing onto the back of the seats and started picking bugs out of the hair of an audience member. It was absolute magic! It took my breath away - it was one of those moments where you wish that everybody you knew was there to see it. Awesome, inspiring, creative, different, daring - I thought to myself - this is great, we need more stuff like this - art matters!" - Myra Thomson



"Seeing my 7 year old daughter Micalla perform on the Port Theatre stage moved me to tears... she has experienced the magic of theatre already and can look forward to many more of these precious opportunities." - Shelley Wilkins Wallace and Family

"An absolutely meaningful piece of acting, for one person to so hold an audience in her hand, marvelous. Bravo! Bravo! Deserves a "Nanaimo" Oscar!" - Auli Toal & Charlotte Brown rave about Shirley Valentine



"... music is so stirring and challenging... It is not uncommon to glance sideways to see my wife's face bathed in tears acknowledging sweet nuances of living memories from her past - what a sheer moment of joy for both of us!" - Mr. and Mrs. Wam



"Whether I was performing, volunteering or just sitting in as an audience member, I never felt so welcome as I did at The Port Theatre. Every time I find myself there, I have nothing less than a breathtaking experience. The Port Theatre has had a major influence on my life!" - Jeremy Roszmann



"My daughter and I shared the experience of watching the National Acrobats of Taiwan perform. Their costumes were brightly coloured and elaborate, reflecting culture and tradition. She will always remember how the acrobats were so brave and courageous. What an incredible experience it was!" - Sarb & Anjali Parmar

Make sure to share your "Port Theatre Story" with others - especially us! We'd love to hear about an experience you've had at The Port Theatre. Send your story to admin@porttheatre.com.





Tell Us Your Stories!

We want to hear your Dance In Vancouver Stories... What impact did this performance have on you? How did it make you feel? What was your personal response? Whether it's one word, a sentence, a metaphor or image, your feedback helps us demonstrate the value and importance of dance to funders and other potential sponsors and supporters. Thank you!

Show title and date:

My response...

Post your experience on the board in the Faris lobby or in the box provided, or hand it to a staff member. You can also email us at info@thedancecentre.ca.

Comments after Peter Bingham & Wen Wei Wang *Thirst*

Heather Bray, Marketing Manager, The Dance Centre, Vancouver, BC www.thedancecentre.ca

White bones dissolving in clean water.

What we think/say is less than the body speaks between crafted movements.
? at first then WOW! Such control and depth of expression! It was a moment
in time!

Together yet part of the universe - separate yet part of the human society.
Riveting in its purity and pace. FOCUS & INTENSITY.

Control, millimetric precision/unquivering stillness-a treat to experience.

Great sense of timelessness, Interesting ideas, stimulating & calming,

First time in ages I let my brain relax & enjoy something unfolding...their world
was full of grace + beauty + questions.

Love what dance in this city offers. Just wish there was more (& more money!).

Thoughtful, difficult & personal journey of two alone, then mutually engaged.

Reminds me of my childhood. Body remembers feeling to move in an artful way.

Thirsting for companionship and communication.

Constant ebb & flow, movement into movement, sound into sound;

A revelation. A meditation. I thirst for more. Thank you.

Magnetic fields shared, opposed. Were they in the same space?

Poetry of both the word & the dance -lyricism with sly wit!

Beautiful - energetic - conscious movement with heart. Principals of soft and
strong, full and empty, yin and yang. Moving me to tears.

Yeah! for dancing no matter what their age! Keep on dancing guys!

My body was being spoken to and it responded with excitement....

Embodies wisdom that a younger body cannot possibly know... something
deeper, richer, wiser; connecting fresh with ancient knowing.



Tell us about your Memorable and Meaningful Arts Experiences during the 2005-06 Season!

1 Where and When?

Performance, Exhibition or Event	_____
Arts Organization/Location	_____
Month/Year	_____
Survey Code (if available)	_____

2 Please describe your personally memorable or meaningful experience. How did you feel? Did it encourage you to think of others, recall a memor or think differently about the future?

3 We hope to describe these memorable arts experiences to others. Would you agree to have your remarks:

- Quoted With Attribution (Your name only)
- Quoted With only your zip/postal code
- Quoted Without Any Attribution at All
- I do not wish my remarks to be quoted

4 Respondent (Optional)

First Name	_____
Last Name	_____

Performance	When?	Memorable/Meaningful Experience	Quoted?	Copy?	Fname	Lna	Postal	Email	Comments
LULLABY of B	2003	This show was REAL -- it consisted of talent	Quoted V	Yes					While we lo
Miami Ballet		On two occasions I had to cancel my evenin	I do not v	Yes	Bridge	Mur	66044	bmurphygw	I also loved
The Music of	October	We expected little; were rewarded with a ren	Quoted V	Yes	Emlin	Nor	66614	EmlinN@ac	Wish you w
Christmas Ve	Dec. 2004	Just a warm & fuzzy feeling to hear those m	Quoted V	Yes	Franci	Car	67152	crestway@y	x
Flamenco Viv	October 7th 2	It was beyond great! Carlota Santana's danc	Quoted V	Yes	astrid	vill	66047	villamil@ku	N/A
rent		I am an alumni of the University of Kansas, s	Quoted V	Yes	debor	goc	66207		
Cats	Feb. 2004?	Wonderful experience, full of emotion and se	Quoted V	No	Sylvia	Ma	66047	maackes@	Any possibi
Cintormell or	Oct or Nov	The music was beautiful and of course the s	Quoted V	No	Gail	Ves	66208	gail.vessels	I loved a stu
John Phillip S	Nov-04	An absolutely memorable performance for a	Quoted V	Yes	O. P. "	Pet	66047	opeter@sur	The Lied Ce
Blind Boys of	February, 200	The Blind Boys of Alabama made me laugh.	Quoted V	Yes	Helen	Hav	66044	hoohawkins	Affordability
Scottish Chris	2004	I felt warm and relaxed and then vitalized as	Quoted V	No	Harriet	Bag	66048	hebleav@y	Do not shar
CATS		the performance was fantastic. the kids wer	Quoted V	Yes	Patrick	Fin	66046	pjcfjinnegar	x
The Five Blind	2/2/2005	A wonderful concert at a spectacular venue.	Quoted V	Yes	Clayto	Cra	67156	guitarslayer	x
Strawberry Fi	Feb-04	I love contemporary American operas, so thi	Quoted V	No	Nikola	Huf	64112	globehead@	x
A Scottish Ch	Dec-04	It was a very meaningful experience becaus	Quoted V	No	Heath	Car	66047	heathbar@l	x
Prague Philha	Oct-04	The audience connection with the performer	Quoted V	No					
YoYo Ma and	Spring 2004 ?	Intrigued by the set and by the unusual instr	Quoted V	No	Barbar	Sch	66049	bschnitker@	No
Ballet		Stimulated, excited after the performance wi	I do not v	Yes	Marilyr	Los	67530	mloss@yah	x
YoYo Ma	Apr-04	I took my daughter to experience the YoYo f	Quoted V	Yes	Bonnie	Nev	66047	bonnienewc	I really valu
Yo Yo Ma and	spring 2004	Yo Yo Ma and the Silk Road Ensemble mad	Quoted V	Yes	Ellen	Rai	66044	ellencr@ku	x
Marine Band, Scottish Chris		These performances are good examples of v	Quoted V	Yes	John	Mo	66049	jmosher@s	x
Scottish Chris	4-Dec	It was a great Christmas season event - insp	Quoted V	Yes	Kerry	Her	66109	herndon.ke	I also attend
Mark Twain T	Nov-04	Actor Hal Holbrook has been performing "M	Quoted V	Yes	Kevin	Boa	66049	kboatright@	x
Pharoh's Dau	Feb-05	I tried something new. I found the music to b	Quoted V	No					
Trout Fishing	2004	We first attended a pre-concert session with	Quoted V	Yes	Amy	Kel	66049		
prague symphonia		conductor as well as the orchestra were out	I do not v	Yes	Bob	Hor	66047	bobhonse@	x

3. Socio-Cultural- To what extent did these arts experiences provide

The top percentage indicates total respondent ratio; the bottom number represents actual number of respondents selecting the option

	1 Not at All	2	3	4	5 A Great Deal
1. Civic/community pride	0% 0	0% 0	0% 0	0% 0	0% 0
2. A sense of place; belonging	0% 0	0% 0	0% 0	0% 0	0% 0
3. Learn about other cultures	0% 0	0% 0	0% 0	0% 0	0% 0
4. Understand more about your cultural heritage	0% 0	0% 0	0% 0	0% 0	0% 0
5. Better relationships with friends and family	0% 0	0% 0	0% 0	0% 0	0% 0
6. Access cultural memory through pageantry, ritual	0% 0	0% 0	0% 0	0% 0	0% 0
7. Communicate norms, beliefs	0% 0	0% 0	0% 0	0% 0	0% 0
8. Establish a legacy	0% 0	0% 0	0% 0	0% 0	0% 0
9. Remember things you've forgotten	0% 0	0% 0	0% 0	0% 0	0% 0

<http://www.zoomerang.com/survey.zgi?p=WEB224X6TQLTW8>

Revealing the Public Value of the Arts

Select one key part of your authorizing environment. Think about what they value. Write phrases describing the value you provide to your community without using the words arts, music, dance, theatre, etc.

What evidence could I/we collect to demonstrate the value that is created?

Economies of Scope



Copyright © 2005 Harvard Business School Publishing Corporation. All rights reserved.

Traditional Bell Curve (Solicitation as Transaction)

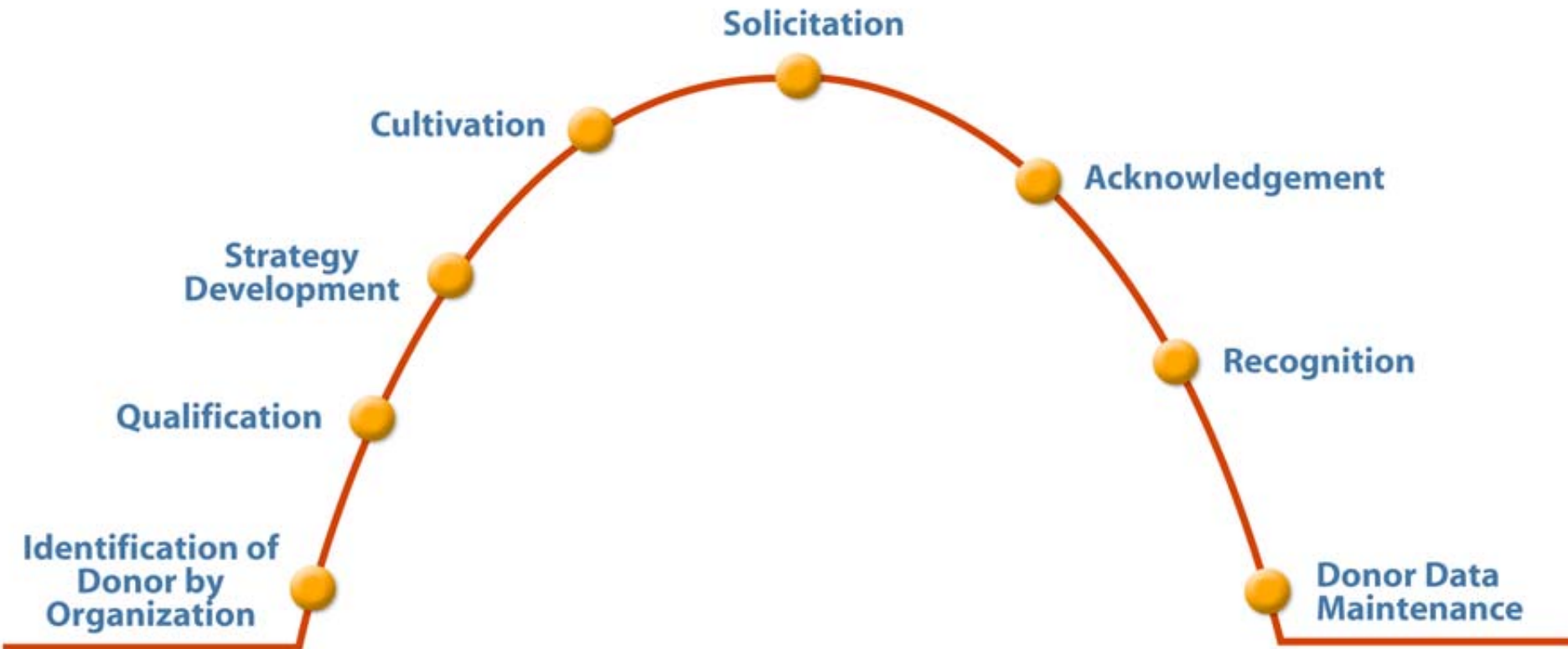

High Impact Philanthropy
Kay Sprinkel Grace, Alan Wendroff

http://stations.cpb.org/tv/grants/ff/02_pbs_dev_conf_keynote.html

Transformational Infinity Loop (Issues/Vision Driven)

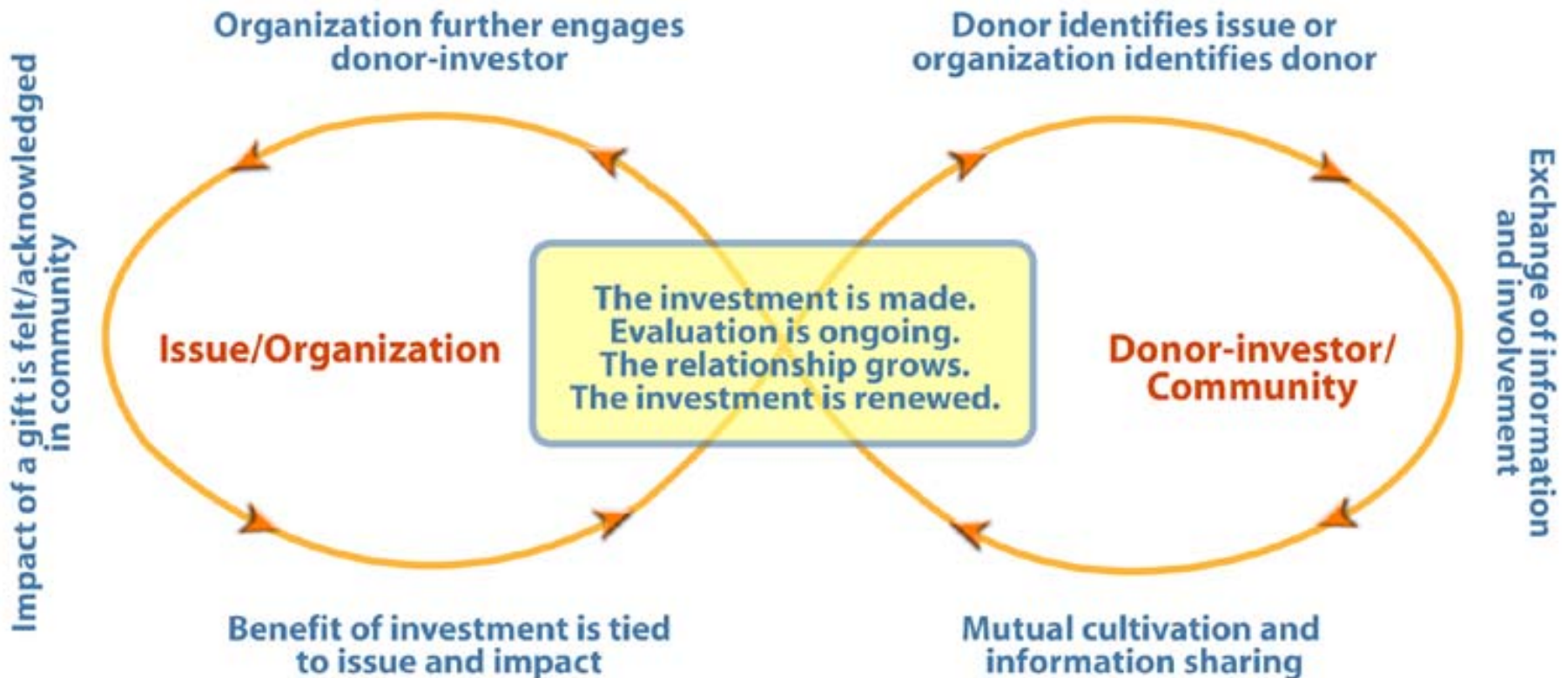

http://stations.cpb.org/tv/grants/ff/02_pbs_dev_conf_keynote.html

Our Voices Together

Building a Safer,
More Compassionate World



Central Asia Institute School Supplies

Your \$20 donation covers the approximate cost of annual school supplies for a student, especially for girls and women, at the Central Asia Institute's schools in rural Pakistan or Afghanistan.



Grassroots International Gardening Tools for an Urban Garden

Your donation of \$75 helps a family help itself and builds community by covering expenses for gardening tools, watering cans, soil and fertilizers to build an urban garden in the Gaza strip.

Next Steps

What key concepts have I learned here that I can use tomorrow?

What next steps will I take?

What next steps could we take together?